

In series

The model is in series and available for the long term.



uEye industrial cameras now also work with IDS peak! We recommend the Software Development Kit for the implementation of new projects. [Learn about the process here and switch now.](#) Please note: The technical data given here was measured using the IDS Software Suite.

Specification

Sensor

Sensor type	CMOS Color
Shutter	Global Shutter / Rolling shutter / Global Start Shutter
Sensor characteristic	Linear
Readout mode	Progressive scan
Pixel Class	1.3 MP
Resolution	1.31 Mpix
Resolution (h x v)	1280 x 1024 Pixel
Aspect ratio	5:4
ADC	10 bit
Color depth (camera)	8 bit
Optical sensor class	1/1.8"
Optical Size	6.784 mm x 5.427 mm
Optical sensor diagonal	8.69 mm (1/1.84")
Pixel size	5.3 µm
Manufacturer	e2v
Sensor Model	EV76C560ACT
Gain (master/RGB)	4x/4x
AOI horizontal	same frame rate
AOI vertical	increased frame rate
AOI image width / step width	16 / 4
AOI image height / step width	4 / 2
AOI position grid (horizontal/vertical)	2 / 2
Binning horizontal	same frame rate
Binning vertical	same frame rate
Binning method	M/C automatic
Binning factor	2
Subsampling horizontal	-
Subsampling vertical	-
Subsampling method	-
Subsampling factor	-

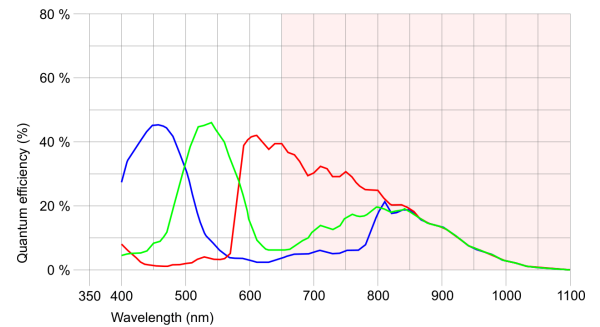

Model

Pixel clock range	7 MHz - 35 MHz
Frame rate freerun mode	25 fps
Frame rate trigger (maximum)	24 fps
Exposure time (minimum - maximum)	0.009 ms - 2000 ms
Power consumption	0.3 W - 0.7 W
Special features	Scaler Sequencer Log mode Sensor hot pixel correction Fine exposure Multi-AOI

Ambient conditions

The temperature values given below refer to the outer device temperature of the camera housing.

Device temperature during operation	0 °C - 55 °C / 32 °F - 131 °F
Device temperature during storage	-20 °C - 80 °C / -4 °F - 176 °F
Humidity (relative, non-condensing)	20 % - 80 %

Connectors

Interface connector	USB 2.0 mini-B
I/O connector	-
Power supply	USB cable

Design

Lens Mount	CS- / C-Mount
IP code	IP30
Dimensions H/W/L	48.6 mm x 44.0 mm x 25.6 mm
Mass	41 g

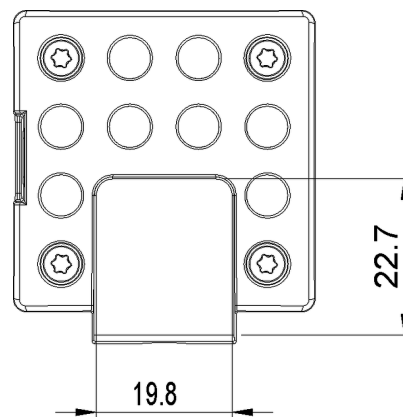
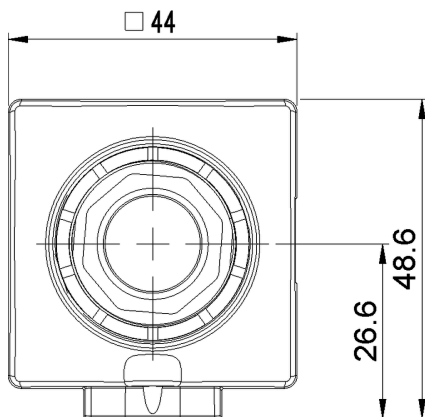

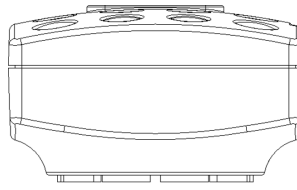
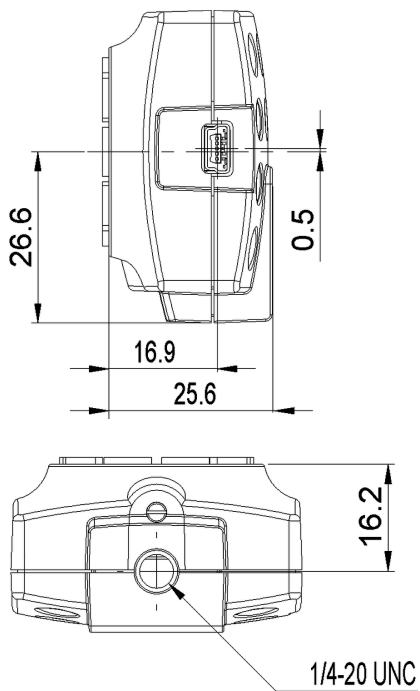

Features

Image Acquisition

Freerun	✓
Software trigger	-
Hardware trigger	✓
Trigger controlled exposure	-
Denoisier	-
Long exposure	-
Line scan	-
Line scan highspeed	-
Global start	✓

Flashing

Flashing	-
PWM flashing	-

Image Adjustments

Auto exposure	-
Auto gain	-
Auto whitebalance	-
Color correction	-
Gamma	-
LUT	-
Mirror/flip	-

On-board Image Processing

Pixel formats	
Region of interest	✓
Decimation (FPGA)	-
Decimation (Sensor)	
Binning (FPGA)	-

Others

Chunks	-
Sequencer	✓
Firmware update	-
1st supported firmware version	3.80



VISION CONSULTANCY
MAKING THE UNSEEN VISIBLE

Thank you for downloading this document from
www.machine-vision-shop.com

If you have any questions, you need help composing the
right package for your application or do you want to order?

Feel free to contact us via e-mail at sales@vision-consultancy.nl or visit our webshop.

Our vision experts are happy to help you.



Natascha Overhof



Christian Cromptvoets



VISION CONSULTANCY

Robert Schumandomein 2
6229 ES Maastricht
The Netherlands

+31 (0) 438 522 651

sales@vision-consultancy.nl
www.machine-vision-shop.com

Scan me to visit
[machine-vision-shop](http://machine-vision-shop.com)

